



Ref: Tender No: IIMV/PMO/T/04/2018-19

Date: April 24, 2018

Tender document for Supply, Installation, and Commissioning of Audio-Visual (AV) design for classrooms & Meeting room at IIM Visakhapatnam.

Last date for submission of technical & Commercial bids	04-5-2018, 3:00 PM
Opening of technical bids	04-5-2018, 4:00 PM
Opening of Commercial Bids	Of only those bidders, who qualify in the technical evaluation.

Address:

Andhra Bank School of Business Building
Andhra University Campus
Visakhapatnam-530003
Phone: +891-2824-444

TABLE OF CONTENTS

Sl.no		Page No
1	Notice Inviting tender	3
2	Tender Details	3
3	Overview	5
4	Terminology	6
5	Eligibility Criteria	7
6	General terms & conditions	8
7	Service Terms & Conditions	10
8	Support and Maintenance Specific Terms	11
9	Terms & Conditions	12
10	Procedure for opening & evaluation of Tender Bids	13
11	Bidders Particulars	14
12	Technical specifications	15
13	List of corporate customers of the bidder	18
14	Integrity pact	19
15	Price bid	26
16	Drawings	39
17	E tender Notice	42

**INDIAN INSTITUTE OF MANAGEMENT VISAKHAPATNAM
OFFICE OF THE PROJECT MANAGER - INFRASTRUCTURE
ANDHRA BANK SCHOOL OF BUSINESS BUILDING
ANDHRA UNIVESITY CAMPUS
VISAKHAPATNAM 530 003**

1. NOTICE INVITING TENDER (NIT)

IIMV/PMO/T/04/2018-19 dated April 24, 2018

SUB: Supply, Installation, and Commissioning of Audio-Visual (AV) Systems for classrooms & Meeting room at IIM Visakhapatnam.

Indian Institute of Management Visakhapatnam invites tenders Supply, Installation and Commissioning of Audio-Visual (AV) Systems for classrooms & Meeting room at IIM Visakhapatnam.

2. Tender details:

1	Ref. No. IIMV/PMO/T/04/2018-19 dated April 24, 2018				
2	Name of the work	Supply, Installation, and Commissioning of Audio-Visual (AV) Systems for classrooms & Meeting room at IIM Visakhapatnam.			
3	Type of Tender	Cost of Tender In Rs	EMD in Rupees	Estimated Cost in Rupees	Time period
	Item Rate	1000/-	1,72,800/-	86,40,000/-	45 days
4.	Tender Cost / Tender document charges of Rs. 1000/- & EMD of Rs. 1, 72,800/- (Rupees One lac seventy two thousand eight hundred only) to be paid through e-Procurement portal while uploading documents.				
5	Last Date for Submission of Tender and for payment of Tender Cost& EMD	May 4, 2018; 3:00 pm			
6	Date and time of opening of tender (Technical Bid)	May 4, 2018 at 4:00 pm.			
7.	Date and time of opening of tender (Commercial Bid)	Of only those bidders, who qualify in the technical evaluation.			

7	Sale of Tender Document	The tender documents can be downloaded from the websites www.tenderwizard.com/IIMV or http://www.iimv.ac.in/tender-notices.html	
8	Place of the submission	Submission through e-portal: www.tenderwizard.com/iimv	
9	Eligibility Criteria	The bidder must meet the eligibility criteria indicated in the Technical Bid Evaluation Process	
10	Regulatory/ Statutory Compliances	The Bidder must have PAN Number, GST Registration Number,	

oOo

INDIAN INSTITUTE OF MANAGEMENT VISAKHAPATNAM

Subject: Supply, Installation, and Commissioning of Audio-Visual (AV) design for classrooms & Meeting room at IIM Visakhapatnam.

Tender details:

3. OVERVIEW:

- a. Indian Institute of Management Visakhapatnam (IIMV, the Institute) was set up in 2015 in Visakhapatnam by the Government of India, Ministry of Human Resource Development. Presently, IIM Visakhapatnam operates from Andhra University Campus.
- b. IIMV is desirous of hiring a contractor for Supply, Installation, and Commissioning of Audio Visual design for classrooms & Meeting room at IIM Visakhapatnam.
- c. Bids are invited from eligible bidders directly based on the eligibility criteria and general terms and conditions mentioned below. Interested bidders may download the copy of the document from websites, i.e. www.tenderwizard.com/IIMV or <http://www.iimv.ac.in/tender-notices.html>.
- d. Interested bidders are required to pay a Tender Cost of Rs.1000/- (Rupees Thousand only) and Earnest Money Deposit (EMD) of Rs. 1,72,800/- (Rupees One lac seventy two thousand eight hundred only) as prescribed in the Notice Inviting Tender through e- procurement portal.
- e. The last date for submission of Technical Bid along with Tender Cost & EMD is May 4, 2018; 3 PM. All such received Technical Bids will be opened on the same day i.e. May 4, 2018 at 4 PM.
- f. A Committee duly constituted by the Competent Authority would evaluate the Technical Bids submitted by the bidders and the Financial Bid (i.e. Commercial or Price Bids) of the short-listed bidders.
- g. The tender document can be downloaded from www.tenderwizard.com/IIMV or <http://www.iimv.ac.in/tender-notices.html>. Any corrigenda or amendments will be posted on the Institute's website only and the Bidders are advised to keep visiting the Institute's website regularly for updates/changes.

4. TERMINOLOGY:

Definitions - Throughout this RFP, unless inconsistent with the subject matter or context:

- i. **Bidder/ Service Provider/ System Integrator / Original Equipment Manufacturer (OEM)**- An eligible entity/firm submitting a Proposal/Bid in response to this RFP
- ii. **Supplier/ Contractor/ Vendor** - Selected Bidder/System Integrator under this RFP/NIT.
- iii. **Company/ Purchaser/ IIM Visakhapatnam**- Reference to the “IIM Visakhapatnam”, “Company” and “Purchaser” shall be determined in same context and referred as “IIM Visakhapatnam”.
- iv. **Proposal/ Bid** - the Bidder’s written reply or submission in response to this RFP/NIT
- v. **RFP/NIT** - the request for proposal (NIT - this document) in its entirety, inclusive of any Addenda that may be issued by IIM VISAKHAPATNAM.
- vi. **Solution/ Services/ Work/ System** - “Solution” or “Services” or “Work” or “System” or “IT System” means all services, scope of work and deliverable to be provided by a Bidder as described in the RFP and include services ancillary to delivery of IT, such as installation, commissioning, transfer of user data, installation of antivirus and other basic applications, configuring email, windows account and other obligation of the Supplier covered under the RFP.
- vii. **IT** as specified within the technical requirement section of this RFP/NIT document.
- viii. **Annual Maintenance Contract (AMC)** - It would be the annual cost of maintenance of hardware / solution / Service

5. ELIGIBILITY CRITERIA:

Bid is open to all Bidders who fulfill the eligibility criteria. The minimum eligibility criteria for selecting the vendors for the purpose stated above have been listed in this section. All bidders are requested to study the pre-qualification criteria listed below carefully and submit the bids only if they fully qualify for bidding for the relevant services.

Sr.No	Criteria	Documents to be scanned and upload
1	The Bidder must be a registered corporate in India registered under the Companies Act 1956 or a Government Organization. The bidder should have been operating in India for atleast five years as of 31 st March 2018	<ul style="list-style-type: none"> • Copy of certificate of Incorporation
2	The bidder shall be a reputable Indian/ Multinational company with primary business in AV Systems; and it must be either an Original Equipment Manufacturer or Authorized System Integrator(s) of the principal OEM, in India.	<ul style="list-style-type: none"> • GST Registration certificate for the said services. • Copy of PAN card
3	The bidder should have positive net-worth as on 31/03/2017. The bidder should have a net solvency of Rs. ONE (1) Crore on the date of issue of tender	<ul style="list-style-type: none"> • Copy of the audited balance sheet of the company (s) • Certificate from the Chartered Accountant • Certificate from Bank Manager of a nationalized/scheduled bank clearly stating the net solvency.
4	The bidder should have an average annual turnover of at least Rs. 1.5 crores during last 3 financial years as on 31/03/2017	<ul style="list-style-type: none"> • Copy of the audited profit & loss statements for each of the last 3 financial years
5	The bidder should have the experience of successfully completing at least three (3) AV integration & Maintenance projects in an educational campus of higher learning like IIMs/ IITs/NITs/Central Universities, of value more than Rs.100 lacs each, in the last 3 years ending as on 31 March 2018	<ul style="list-style-type: none"> • Work Completion Certificates and copies of client citation / purchase order / work orders showing all the details sought • Reference for each of the projects containing the following information - Name of organization, TDS Certificate Details,

		individual/s to contact, phone number and address
6	The bidder should have an ISO 9001 Certification	<ul style="list-style-type: none"> • Copy of the valid certificates from authorized agencies
7	The bidder must not be blacklisted by a Central / State / Local Government Organization / Institution / PSU	<ul style="list-style-type: none"> • Self-declaration, certified by auditor

6. General Terms and Conditions:

1. Indian Institute of Management Visakhapatnam reserves the right to accept or reject any or all the tenders or cancel this process at any time without assigning any reason whatsoever.
2. The bidders, who do not meet the eligibility criteria; or do not submit all the necessary documents in support of the eligibility criteria; or do not submit documents that are complete and valid - shall be disqualified.
3. Bidders are requested to download the documents from www.tenderwizard.com/IIMV or <http://www.iimv.ac.in/tender-notices.html> for submission. Cost of tender documents shall be deposited as given in the Notice Inviting Tender.
4. Contract Period: The contract shall complete all the works awarded within 45 days from the date of award of contract.
5. The Bidder must submit the OEM Authorization letter (MAF) for all active components under the present Scope of Works.
6. The financial bids of only short-listed bidders who have qualified in the technical evaluation shall be opened. The decision of IIMV on technical bid evaluation is final and binding on all the bidders. Only the technically qualified bidders shall be intimated the date of opening of the financial bids.
7. If the last date of opening of the offer coincides with a holiday, then the next working day shall be receiving/opening date.
8. **In the event of increase in the taxes and levies implemented by the Government(s) during the contract period, the same shall be paid by IIMV at actual, on production of Government(s) Notification and proof of payment. Similarly, in case of any reduction in the taxes and levies, the same must be passed on to IIMV by the contractor.**
9. Validity of prices quoted in financial bids: The validity of prices quoted in the financial bid by the bidders is for a period of 60 days from the date of opening of the financial bid.

10. IIMV reserves the right to reject all or any of the bids at any stage without assigning any reasons whatsoever and the decision of IIMV in the matter shall be final and binding on the bidders.
11. All “Conditional Bids” shall be rejected.
12. IIMV shall correspond only with the shortlisted bidders.
13. Any form of canvassing/influencing will attract rejection of bid submitted by the bidder and the Institute reserves the right to take such penal action (e.g. blacklisting the Bidder for the present and future etc.) as it deems fit.
14. Irrespective of the offers received or their competitiveness, the final decision on choosing a bidder, will vest in entirety with the IIMV.
15. The bidder is expected to examine all instructions, terms and specifications in the tender document. Failure to furnish all information required or to submit a bid not substantially responsive to the tender document in every respect will be at the bidder’s risk and may result in the rejection of the bid. Prior to detailed evaluation, the Institute will determine the substantial responsiveness of each bid to the tender document. A substantially responsive bid is one which conforms to all the terms and conditions of the bidding/tender document and is without any material defects and deviations. Deviations from, or objections or reservations to critical provisions such as those concerning qualification criteria, availability of facilities and amenities as needed, availability of government/statutory approvals and clearances, ready and explicit willingness to accept and honour the terms and conditions of contract etc. will be deemed to be material deviations. If a bid is not substantially responsive, it will be rejected by the Institute and may not subsequently be made responsive by the bidder by correction of the non-conformity. Only those bidders whose Technical bids have been found substantially responsive would be informed by the Institute about their responsiveness. The Institute will evaluate and compare the financial bids of only those Technical bids which have been determined to be substantially responsive. The Institute will award the contract to the successful bidder who has been determined to qualify to perform the Contract satisfactorily, and whose bid has been determined to be substantially responsive, and is the lowest evaluated bid.
16. If any stage it is found that any of the details/documents furnished by the bidder is false/misleading/fabricated, his/her/its bid would be liable for cancellation without intimation to the bidder.
17. The offer should remain valid for 60 days. During the validity period of the offer, the bidder should not withdraw/modify the offer in terms of terms and conditions quoted in the Technical Qualification.
18. Notwithstanding anything contained above, the Institute reserves the right to reject all or any bid as recommended by the Tender Committee and is not bound to divulge any reason to the unsuccessful bidders

19. Payments: 90% of the Payments shall be made on completion of contracted works and balance 10 % would be released against submission bank guarantee for a period of three years towards post commissioning. TDS and other taxes/duties will be deductible as applicable as per Government of India rules.
20. Mode of Issue of Notice: Any notice sent by Speed Post only by either party to the addresses recorded in the Contract shall be deemed to have been properly served for any of the purposes mentioned herein.
21. Advances: IIM Visakhapatnam will not pay any advances, against supply material or against Proforma invoice to vendor.
22. The contractor shall not employ any person who has not completed eighteen years of age.
23. The contractor shall comply all the statutory and legal provisions as laid down under various Labour Laws from time at his own cost. In case of violation of any statutory provisions or any other applicable laws, IIM Visakhapatnam will not be held responsible.
24. Arbitration: All disputes in connection with the execution of contract shall be settled under the provisions of Arbitration and Conciliation Act 1996 and the rules framed there under and in force shall be applicable to such proceedings. The Competent Authority of IIM Visakhapatnam or a person nominated by him/her shall be the sole Arbitrator. The cost of arbitration shall be borne equally by both the parties.
25. Jurisdiction: All disputes shall be subject to the Civil Court jurisdiction of Visakhapatnam, Andhra Pradesh, India only.

7. Service Terms & Conditions

1. The vendor/contractor will be responsible for any mishap or accident during the installation /maintenance of the equipment which may occur due to negligence on part of the vendor.
2. The vendor/ contractor shall pay and be responsible for payment of all taxes, duties, levies, fees, costs or charges in respect of the products/ services rendered to IIM VISAKHAPATNAM as part of the contract. The vendor/contractor shall indemnify and keep indemnified IIM Visakhapatnam against claims in respect of above taxes, levies, duties, fees, costs, charges etc. All of the aforesaid taxes, duties, levies, fees, cost and charges shall be to the vendor/ contractor's account and IIM Visakhapatnam shall not be required to pay any additional or extra amount on account of variation of the above charges if any, till the completion of work as per the contract to the satisfaction of IIM

Visakhapatnam and no extra claim on this account will be entertained in any case.

8. Support and Maintenance Specific Terms

- a. The vendor/ contractor will provide on-site comprehensive maintenance services including repairs/ replacement of faulty parts for all Equipment.
- b. The vendor/ contractor will undertake that supplies of necessary maintenance equipment, tools and spare parts will be made available on a continuous basis.
- c. The vendor/ contractor should provide equivalent or higher stand-by equipment in case the problem is not resolved within the stipulated time.
- d. In case the system is found non-repairable or is taking prolonged time in repair, it is vendor's liability to provide a standby system within agreed time as per SLA. This time shall be from the time of call logging and not the time of call attending.
- e. Product provided as a standby shall be a workable solution and may or may not be the exact configuration product. In such cases, permanent replacement shall be provided with equivalent or higher configuration part/system only within maximum 7 days of call logging. This shall be done at no extra cost to IIM Visakhapatnam.
- f. The cost and consequences, if any, would be borne by the vendor/ contractor for the maintenance of the equipment.
- g. All parts replaced by the vendor must be new of same specification and make or, if such parts are not available in the market, parts of different make and quality would be accepted provided such request is made in writing.
- h. The Company should have enough spares in its inventory to service the equipment during the term of agreement. The spares should be of good quality and should not endanger the brand-integrity of IIM Visakhapatnam equipment.
- i. Insurance and any other charges for products/parts in movement for repair to and from vendor/ contractor's workshop shall be liability of the vendor/ contractor. However, IIM Visakhapatnam shall provide necessary documents required for legal bodies like Octroi Check-post, etc.

The Vendor should undertake to:

Depute Engineer to pay quarterly statutory visits (4 per year) and attend to all break down calls as and when required within the limit mentioned here in above, to each of the locations in IIMV (where system is installed) for maintenance of the equipment.

1. Depute Engineer to repair faults arising due to and because of faulty, incorrect or incomplete maintenance work and also arising out of any other technical faults.
2. No separate charges will be paid for such visits.
3. The Engineer Will carry adequate and suitable tools, equipment's, spares and other required materials for maintenance work.
4. The Contractor will ensure that Systems are in perfect working conditions all through.
5. The fault repair calls will be attended immediately, but not later than 12 hours of receipt of intimation.
6. Contractor will maintain a complaint register at his office and each complaint will be given a serial number of easy management.
7. The Contractor will prepare a servicing Memo in quadruplicate and get the same signed by the Manager/Authorized Official on satisfactory completion of the work. One copy of the same will be handed over to the location immediately.
8. The Contractor will submit the following reports of all the equipment's and locations of the institute within 20days of the end of each quarter.
 - (i) One copy of the Servicing Memo(s) duly signed by the Authorized Official with stamp.

9. Terms & Conditions

1. Items included in the desired solution proposal must carry 3 years onsite comprehensive warranty.
2. Service level agreement for support includes 4 hrs., response and next business day resolution on 8*6 basis but with standby /alternative provided immediately. This applies in all cases except server, which must have 24*7 support.
3. One support engineer is required, initially till the completion of installation and will be reviewed after words on mutually agreed terms.
4. Delivery of all the items should necessarily within "Four (4) weeks" from date of order, followed by installation.

5. Bidders are expected to substantiate their offers by providing all necessary datasheets and testimonials of existing installations. Bids with commercial for all the items will be selected for subsequent process.
6. Rates quoted by bidder in the Price bid is Inclusive of Supply, Installation, Commissioning and three years onsite comprehensive maintenance services

10. **Procedure for Opening & Evaluating of Tender Bids (Technical):**

- a) The Committee or a Sub-Committee constituted by the Institute will open the Technical bids in the presence of the bidders or their duly authorized representatives (max one person/representative per bidder), on the date and at the time herein specified.
- b) Detailed evaluation of the Technical Bids then follows, about their conformity with the requirement specifications as well as other relevant factors. For the bids that qualify in the first stage of evaluation, the second stage, where the Price bids of the finally short-listed bidders (only) would be opened and evaluated.

ANNEXURE-I

Bidder's Particulars

Bidders Particulars- Annexure I		
Sl.No	Particulars	Details
1	Bidder's name/ Organization Name	
2	Address for communication	
3	Contact Details	
	Designation	
	Telephone Number office	
	Mobile Number	
	Email Id	
4	PAN Number	
5	GST registration number	
6	Bank Particulars	
	Account name	
	Type of A/c: (SB/CA/CC)	
	A/c No.	
	IFS Code	
	Name of the Bank	
	Branch	

Please attach copies of certificates issued by the principal company in this regard Note:

a) The bidder should attach the relevant documents related to financial details such as:

- Copy of the audited financials for last three years
- Copy of the audited Profit & Loss Statements for each of the last 3 financial years
- Self-declaration, declaring bidder has not been blacklisted by a Central/ State / Local Government Organization/ Academic Institution /PSU
- The bidder shall have at least one support office in Andhra Pradesh preferably at Visakhapatnam. Copy of the relevant trade license issued by State Govt. or competent local body mentioning the address.
- Copy of GST Registration

ANNEXURE-II

Technical specifications

A. Requirement summary

IIM at Vishakhapatnam intended to build the IT infrastructure at the existing building of Andhra University with following requirements

Classroom 1

Size of classroom - 70 seats 10 m x 12.1 m (140 SQM) at IIM-Vishakhapatnam should be equipped

- a) Projectors: Two projectors will be provisioned at classroom-1 where both the projectors will be used for content sharing from Local Faculty Laptop.
- b) Microphones (MIC): The Neck Hanging MIC should be provisioned for Faculty/professor along with necessary accessories to capture his/her voice for local classroom session.
- c) Amplifiers and speakers: The Amplifiers and speakers should be provisioned at this class room for amplifying the Voice coming from faculty MIC /Program audio, to provide uniform SPL across the classroom for local and remote classroom scenarios.
- d) The size of the classroom is Classroom-1 size: 10m X 12.1m. Layout of the Classroom is attached in floor plan section
- e) The Specification of projector, switcher and touch panel is mentioned in Section Technical specifications:

The components required for the overall audio and video integration such as, Projectors, Amplifiers, and MICs with Control system, Mixer and Video switcher is mentioned in BOQ system. Integrators must quote accordingly

Classroom-2

The size of the classroom is 35 seats 9.1 m x 7.6 m (69.23 SQM) should be equipped

- a) Projectors: One projector will be provisioned at classroom-1 and used for content sharing either from Local Faculty Laptop.
- b) Microphones (MIC): The Neck Hanging MIC should be provisioned for Faculty/professor along with necessary accessories to capture his/her voice for local classroom session.
- c) Amplifiers and speakers: The Amplifiers and pair of surface mount speakers with 8” woofer should be provisioned at this class rooms for amplifying the Voice coming from faculty MIC /Program audio, for local and remote classroom scenarios.

- d) The size of the classroom is Classroom-2 size: 9.1m X 7.6m Layout of the Classroom is attached in floor plan section
- e) The Specification of projector, switcher and touch panel is mentioned in Section Technical specifications:

The components required for the overall audio and video integration such as, Projectors, Amplifiers, and MICs with Control system, Mixer and Video switcher is mentioned in BOQ system. Integrators must quote accordingly

Meeting Rooms

The size of the Meeting room 10x 5.1 (510 SQM) should be equipped

- a) The meeting rooms should have provision for ultrashort throw Interactive projector.
- b) The room should can receive or dialling any UC based calls.
- c) Should have USB based PTZ HD camera and Speakerphone.

B. Technical specifications

Sl.no	Technical specification	Compliance YES/NO
Class Room 1		
1.	Display System classroom should be installed with 2 ultra-short throw projectors. The projector should be wall mounted and it should be configured with white boards	
2.	Confidence Monitor- A 55” Full HD LED Monitor will be used as confidence monitor for the professor.	
3.	Audio System the audio system should have 4 channels, Class D - Ripple Suppression, energy start amplifier, with 200 watts per channel and two-way flat field ceiling speakers for uniform coverage.	
4.	Mic System- the classroom should have rack mounted 8 channel AEC digital mixer, Dual Wearable HD microphone w/ RF Armor technology.	
5.	VGA & HDMI Input Wall Plate based Twisted Pair Transmitter for the Laptop	
6.	HDMI Wall Plate Transmitter for the room computer	
7.	All in One 8x4 4K Presentation Matrix switcher, scaler and control processor. Switcher should have 6 x Direct HDMI & 2 x Twisted Pair inputs, 4 x HDMI & 2 x Twisted Pair Outputs. Control processor w/ 3 x RS-232 ports, 4 x Digital IO, 4 x IR/Serial & 4 x Relay. Audio Mixer, Audio De-embedder and Master audio output	
8.	7” Pro series Wired Touch Panel, PoE powered lectern mountable	

9.	Wireless presenter unit for windows/ MAC/Android	
10.	21.5" IPS Pen Display, Wacom tablet and relevant video and control system	

Class Room 2		
1.	Display System classroom should be installed with 1 ultra-short throw projector. The projector should be wall mounted and it should be configured with white board	
2.	Audio System the audio system should be 4 channel, Class D - Ripple Suppression, energy start amplifier, with 200 watts per channel and two-FOH Speakers	
3.	Mic System- the classroom should have rack mounted 8 channel AEC mixer, Dual Wearable HD microphone w/ RF Armor technology.	
4.	VGA & HDMI Input Wall Plate based Twisted Pair Transmitter for the Laptop	
5.	All in One 8x2 4K Presentation Matrix switcher, scaler and control processor. Switcher should have 6 x Direct HDMI & 2 x Twisted Pair inputs, 2 x HDMI & 2 x Twisted Pair Outputs. Control processor w/ 3 x RS-232 ports, 4 x Digital IO, 4 x IR/Serial & 4 x Relay. Audio Mixer, Audio De-embedder and Master audio output	
6.	7" Pro series Wired Touch Panel, PoE powered lectern mountable	
7.	Wireless presenter unit for windows/ MAC/Android	

Meeting Room		
1.	Display System meeting room should be installed with 1 ultra-short throw interactive projector. The projector should be wall mounted and it should be configured with white board	
2.	Audio System the audio system should be have stereo amplifier, with 15 watts per channel and two-FOH Speakers	
3.	Audio System - USB based Speakerphone for UC Calls should have 2 x extended microphones for greater pickup coverage.	
4.	VGA & HDMI Input Wall Plate Twisted Pair Transmitter /Receiver Pair with user defined auto-switching feature for the Laptop connectivity to the projector	
5.	Table Mounted Button panel w/ 6 x buttons, 1 x volume control nob, 2 x RS-232, 2 x relay, 1 x IR & 1 x Digital IO ports for room controls.	
6.	Wireless presenter unit for windows/ MAC/Android	

ANNEXURE-III

LIST OF CORPORATE CUSTOMERS OF THE BIDDER

The bidder must provide the details as per the below format for similar pan-India branch rollout projects of at least three customers having used/ordered/working with 90% of the given BOM.

Sl.No	Name of the Client, Contact person, Designation & Telephone No.	Date of the Assignment	Details of the assignment done for the Client with Product name, Model etc.
1			
2			
3			
4			

Note: The list should include at least three corporate clients.

- Work Completion Certificates and copies of client citation / purchase order / work orders showing all the details sought

INTEGRITY PACT

To,

.....,
.....,
.....

Sub: NIT No. Tender No: IIMV/PMO/T/04/2018-19 for the work of “Supply, Installation, Commissioning and Audio-Visual (AV) design for classrooms & Meeting room at IIM Visakhapatnam”

Dear Sir,

It is here by declared that IIM Visakhapatnam is committed to follow the principle of transparency, equity and competitiveness in public procurement. The subject Notice Inviting Tender (NIT) is an invitation to offer made on the condition that the Bidder will sign the integrity Agreement, which is an integral part of tender/bid documents, failing which the tenderer/bidder will stand disqualified from the tendering process and the bid of the bidder would be summarily rejected.

This declaration shall form part and parcel of the Integrity Agreement and signing of the same shall be deemed as acceptance and signing of the Integrity Agreement on behalf of the IIM Visakhapatnam.

Yours faithfully

Project Manager- Infrastructure

INTEGRITY PACT (IP)

(Bidder shall submit the Integrity Pact on a non-judicial stamp paper of ₹100/- duly signed by the person(s) signing the bid)

This Integrity Agreement is made at on this day of 20__

BETWEEN

The Director, IIM Visakhapatnam represented through _____, (Hereinafter referred as the IIM Visakhapatnam, Andhra Bank School of Business Building, Andhra University Visakhapatnam - 530003, ‘Principal/Owner’, which expression shall unless repugnant to the meaning or context hereof include its successors and permitted assigns)

AND

.....
..... (Name and Address of the Individual/firm/Company)
through.....
(Hereinafter referred to as the (Details of duly authorized signatory) “Bidder/Contractor” and which expression shall unless repugnant to the meaning or context hereof include its successors and permitted assigns)

Preamble

WHEREAS the Principal / Owner has floated the Tender (NIT No. IIMV/PMO/T/04/2018-19) (hereinafter referred to as “Tender/Bid”) and intends to award, under laid down organizational procedure, contract for “Supply, Installation, Commissioning and Audio Visual design for classrooms & Meeting room at IIM Visakhapatnam”. hereinafter referred to as the “Contract”.

AND WHEREAS the Principal/Owner values full compliance with all relevant laws of the land, rules, regulations, economic use of resources and of fairness/transparency in its relationship with its Bidder(s) and Contractor(s).

AND WHEREAS to meet the purpose aforesaid both the parties have agreed to enter into this Integrity Agreement (hereinafter referred to as “Integrity Pact” or “Pact”), the terms and conditions of which shall also be read as integral part and parcel of the Tender/Bid documents and Contract between the parties.

NOW, THEREFORE, in consideration of mutual covenants contained in this Pact, the parties hereby agree as follows and this Pact witnesses as under:

Article 1: Commitment of the Principal/Owner

The Principal/Owner commits itself to take all measures necessary to prevent corruption and to observe the following principles:

1. No employee of the Principal/Owner, personally or through any of his/her family members, will in connection with the Tender, or the execution of the Contract, demand, take a promise for or accept, for self or third person, any material or immaterial benefit which the person is not legally entitled to;
2. The Principal/Owner will, during the Tender process, treat all Bidder(s) with equity and reason. The Principal/Owner will, in particular, before and during the Tender process, provide to all Bidder(s) the same information and will not provide to any Bidder(s) confidential / additional information through which the Bidder(s) could obtain an advantage in relation to the Tender process or the Contract execution.
3. The Principal/Owner shall endeavor to exclude from the Tender process any person, whose conduct in the past has been of biased nature. If the Principal/Owner obtains information on the conduct of any of its employees which is a criminal offence under the Indian Penal code (IPC)/Prevention of Corruption Act, 1988 (PC Act) or is in violation of the principles herein mentioned or if there be a substantive suspicion in this regard, the Principal/Owner will inform the competent vigilance official and in addition can also initiate disciplinary actions as per its internal laid down policies and procedures.

Article 2: Commitment of the Bidder(s)/Contractor(s)

1. It is required that each Bidder/Contractor (including their respective officers, employees and agents) adhere to the highest ethical standards, and report to the IIM Visakhapatnam / Department all suspected acts of fraud or corruption or Coercion or Collusion of which it has knowledge or becomes aware, during the tendering process and throughout the negotiation or award of a contract.
2. The Bidder(s)/Contractor(s) commits himself to take all measures necessary to prevent corruption. He commits himself to observe the following principles during his participation in the Tender process and during the Contract execution:
 - a) The Bidder(s)/Contractor(s) will not, directly or through any other person or firm, offer, promise or give to any of the Principal/Owner's employees involved in the Tender process or execution of the Contract or to any third person any material or other benefit which he/she is not legally entitled to, in order to obtain in exchange any advantage of any kind whatsoever during the Tender process or during the execution of the Contract.
 - b) The Bidder(s)/Contractor(s) will not enter with other Bidder(s) into any undisclosed agreement or understanding, whether formal or informal. This applies in particular to prices, specifications, certifications, subsidiary

contracts, submission or non-submission of bids or any other actions to restrict competitiveness or to cartelize in the bidding process.

- c) The Bidder(s)/Contractor(s) will not commit any offence under the relevant IPC/PC Act. Further the Bidder(s)/Contractor(s) will not use improperly, (for the purpose of competition or personal gain), or pass on to others, any information or documents provided by the Principal/Owner as part of the business relationship, regarding plans, technical proposals and business details, including information contained or transmitted electronically.
- d) The Bidder(s)/Contractor(s) of foreign origin shall disclose the names and addresses of agents/representatives in India, if any. Similarly, Bidder(s)/Contractor(s) of Indian Nationality shall disclose names and addresses of foreign agents/representatives, if any. Either the Indian agent on behalf of the foreign principal or the foreign principal directly could bid in a tender but not both. Further, in cases where an agent participates in a tender on behalf of one manufacturer, he shall not be allowed to quote on behalf of another manufacturer along with the first manufacturer in a subsequent/parallel tender for the same item.
- e) The Bidder(s)/Contractor(s) will, when presenting his bid, disclose any and all payments he has made, is committed to or intends to make to agents, brokers or any other intermediaries in connection with the award of the Contract.
- f) The Bidder(s)/Contractor(s) will not instigate third persons to commit offences outlined above or be an accessory to such offences.
- g) The Bidder(s)/Contractor(s) will not, directly or through any other person or firm indulge in fraudulent practice means a willful misrepresentation or omission of facts or submission of fake/forged documents in order to induce public official to act in reliance thereof, with the purpose of obtaining unjust advantage by or causing damage to justified interest of others and/or to influence the procurement process to the detriment of the IIM Visakhapatnam interests.
- h) The Bidder(s)/Contractor(s) will not, directly or through any other person or firm use Coercive Practices (means the act of obtaining something, compelling an action or influencing a decision through intimidation, threat or the use of force directly or indirectly, where potential or actual injury may befall upon a person, his/her reputation or property to influence their participation in the tendering process).

Article 3: Consequences of Breach

Without prejudice to any rights that may be available to the Principal/Owner under law or the Contract or its established policies and laid down procedures, the

Principal/Owner shall have the following rights in case of breach of this Integrity Pact by the Bidder(s)/Contractor(s) and the Bidder/ Contractor accepts and undertakes to respect and uphold the Principal/Owner's absolute right:

1. If the Bidder(s)/Contractor(s), either before award or during execution of Contract has committed a transgression through a violation of Article 2 above or in any other form, such as to put his reliability or credibility in question, the Principal/Owner after giving 14 days' notice to the contractor shall have powers to disqualify the Bidder(s)/Contractor(s) from the Tender process or terminate/determine the Contract, if already executed or exclude the Bidder/Contractor from future contract award processes. The imposition and duration of the exclusion will be determined by the severity of transgression and determined by the Principal/Owner. Such exclusion may be forever or for a limited period as decided by the Principal/Owner.
2. Forfeiture of EMD/Performance Guarantee/Security Deposit: If the Principal/Owner has disqualified the Bidder(s) from the Tender process prior to the award of the Contract or terminated/determined the Contract or has accrued the right to terminate/determine the Contract according to Article 3(1), the Principal/Owner apart from exercising any legal rights that may have accrued to the Principal/Owner, may in its considered opinion forfeit the entire amount of Earnest Money Deposit, Performance Guarantee and Security Deposit of the Bidder/Contractor.
3. Criminal Liability: If the Principal/Owner obtains knowledge of conduct of a Bidder or Contractor, or of an employee or a representative or an associate of a Bidder or Contractor which constitutes corruption within the meaning of IPC Act, or if the Principal/Owner has substantive suspicion in this regard, the Principal/Owner will inform the same to law enforcing agencies for further investigation.

Article 4: Previous Transgression

- 1) The Bidder declares that no previous transgressions occurred in the last 5 years with any other Company in any country confirming to the anticorruption approach or with Central Government or State Government or any other Central/State Public Sector Enterprises in India that could justify his exclusion from the Tender process.
- 2) If the Bidder makes incorrect statement on this subject, he can be disqualified from the Tender process or action can be taken for banning of business dealings/ holiday listing of the Bidder/Contractor as deemed fit by the Principal/ Owner.
- 3) If the Bidder/Contractor can prove that he has resorted / recouped the damage caused by him and has installed a suitable corruption prevention system, the Principal/Owner may, at its own discretion, revoke the exclusion prematurely.

Article 5: Equal Treatment of all Bidders/Contractors/Subcontractors

- 1) The Bidder(s)/Contractor(s) undertake(s) to demand from all subcontractors a commitment in conformity with this Integrity Pact. The Bidder/Contractor shall be responsible for any violation(s) of the principles laid down in this agreement/Pact by any of its Subcontractors/sub-vendors.
- 2) The Principal/Owner will enter into Pacts on identical terms as this one with all Bidders and Contractors.
- 3) The Principal/Owner will disqualify Bidders, who do not submit, the duly signed Pact between the Principal/ Owner and the bidder, along with the Tender or violate its provisions at any stage of the Tender process, from the Tender process.

Article 6- Duration of the Pact

This Pact begins when both the parties have legally signed it. It expires for the Contractor/Vendor 12 months after the completion of work under the contract or till the continuation of defect liability period, whichever is more and for all other bidders, till the Contract has been awarded. If any claim is made/lodged during the time, the same shall be binding and continue to be valid despite the lapse of this Pacts as specified above, unless it is discharged/determined by the Competent Authority, IIM Visakhapatnam.

Article 7- Other Provisions

- 1) This Pact is subject to Indian Law, place of performance and jurisdiction is the Headquarters of the Division of the Principal/Owner, who has floated the Tender.
- 2) Changes and supplements need to be made in writing. Side agreements have not been made.
- 3) If the Contractor is a partnership or a consortium, this Pact must be signed by all the partners or by one or more partner holding power of attorney signed by all partners and consortium members. In case of a Company, the Pact must be signed by a representative duly authorized by board resolution.
- 4) Should one or several provisions of this Pact turn out to be invalid; the remainder of this Pact remains valid. In this case, the parties will strive to come to an agreement to their original intentions.
- 5) It is an agreed term and condition that any dispute or difference arising between the parties with regard to the terms of this Integrity Agreement / Pact, any action taken by the Owner/Principal in accordance with this Integrity Agreement/ Pact or interpretation thereof shall not be subject to arbitration.

Article 8- LEGAL AND PRIOR RIGHTS

All rights and remedies of the parties hereto shall be in addition to all the other legal rights and remedies belonging to such parties under the Contract and/or law and the same shall be deemed to be cumulative and not alternative to such legal rights and remedies aforesaid. For the sake of brevity, both the Parties agree that this Integrity Pact will have precedence over the Tender/Contact documents with regard any of the provisions covered under this Integrity Pact.

IN WITNESS WHEREOF the parties have signed and executed this Integrity Pact at the place and date first above mentioned in the presence of following witnesses:

..... (For and on behalf of
Principal/Owner)

..... (For and on behalf of
Bidder/Contractor)

WITNESSES:

1..... (Signature, name and address)

2..... (Signature, name and address)

Place:

Dated:

Price Bid

Sl.No	Item Description	Make	Model	Qty	Unit Price /Rate (INR)	Amount (INR)	GST amount	Total Amount (INR)
1	2	3	4	5	6	7	8	9
						7=(5*6)		9=(7+8)
A	60 Seater Classroom							
a)	Display System							
1	Ultra Short Throw Projector LCD Technology - 3500 Lumens, WXGA Resolution (1280x800) w/ HDMI & VGA Inputs	Epson	EB-675Wi	2		0		0
2	Ultra Short Throw Projector Wall Mount bracket	Epson	ELPMB46	2		0		0
3	Confidence Monitor - 55" Diagonal Professional Grade Display with RS-232 Port	LG	55SE3Kb	1		0		0

4	Thin profile wall mount bracket with tilt for 55" display	Integrator	Custom	1		0		0
b)	Audio System (Mic System)							0
1	Rack mount 2-Channel, XLR/ ¼" I/O, w/o mics (Includes Base Station, Charger Base, Power Supply)	Revolabs	HD Venue 03-HDVENU-03-NM	1		0		0
2	HD Microphone, RF-Armor™ Wearable	Revolabs	Wearable 03-HDEXEMICEU-11	2		0		0
3	Antenna Extension Kit for 4-channel Solo Executive/Executive HD/HD Venue	Revolabs	01-ANTEXEC4-KIT	1		0		0
4	8 channel AEC microphone mixer with 4 Line Inputs and 8 Line outputs w/ built in USB Interface	Extron	DMP 128 Plus C 60-1512-01	1		0		0
c)	Audio System (Amplifier & Speaker)							0

1	Four Channel Amplifier - 200 Watts Per Channel	Extron	XPA 2004 60-563-02	1		0		0
2	Full-Range Flat Field® Speakers with Low Profile Enclosure and 70/100 V Transformer(Pairs)	Extron	FF-220T 42-141-23	3		0		0
3	16 Port Network Switch	Dlink	Dlink	1		0		0
d)	Video System							0
1	21.5" IPS pen display HD Resolution combines multi-finger touch capabilities with Wacom's patented, cordless, battery-free pen technology	Wacom	DTH-2242	1		0		0
2	Two USB A Female to Two USB A Female on 10" Pigtailed- Table Plate to be mounted on the Lectern	Extron	(70-454-13)	1		0		0
3	USB Patch Cables	Integrator	Custom	2		0		0

e)	Video & Control System							0
1	Male to Male VGA Micro HR with Audio Cables	Extron	MVGA-A M-M/6 (26-566-02)	2		0		0
2	DTP Transmitter for MK Junction Boxes	Extron	DTP T MK 4K 231 60-1533-12	2		0		0
3	Two Input DTP Transmitter for HDMI and VGA with Audio Embedding - Decorator-Style Wallplate	Extron	DTP T UWP 4K 232 D 60-1755-12	1		0		0
4	8x4 Seamless 4K Scaling Presentation Matrix Switcher with DTP Extension and Control Processor	Extron	DTP CrossPoint 84 4K IPCP SA 60-1382-12	1		0		0
5	DTP Receiver for HDMI - Decorator-Style Wallplate	Extron	DTP R HWP 4K 231 D 60-1531-13	3		0		0
6	7" Wall Mount Touchlink Pro Touchpanel	Extron	TLP Pro 725M 60-1563-03	1		0		0
7	Power Injector for XTP and Pro Series Control Systems	Extron	XTP PI 100 60-1233-01	1		0		0

8	IP Link Pro Control Processor w/ 3 RS232 Ports	Extron	IPL Pro S3 60-1413-01	1		0		0
9	Ultra Flexible High Speed HDMI Cables-6'	Extron	HDMI Ultra/6 26-663-06	12		0		0
f)	Misc							0
1	Micro Tower- Intel® Core™ i5-7500 with Intel® HD Graphics 630 (3.4 GHz base frequency, up to 3.8 GHz with Intel® Turbo Boost Technology, 6 MB cache, 4 cores) Internal drive 1 TB 7200 rpm SATA 16 GB NVMe™ Intel® Optane™ Memory for storage acceleration, Intel® HD Graphics 630 HP USB Business Slim Keyboard HP USB Hardened Mouse Windows 10 Pro 64	HP	ProDesk 400G4 Small Form Factor PC	1		0		0

2	IP controlled Power conditioner 230 volt	APC	AP7921	1		0		0
3	Wireless Presentation Unit	WePreset	WiPG1000	1		0		0
4	18U Customised Closed Equipment rack	Integrator	Modular	1		0		0
5	Cables and Connectors Includes Audio, Speaker, Control, Microphone cables, Mounting accessories, IEC Connectors etc	Integrator	Various	1		0		0
B	35 Seater Classroom							0
a)	Display System							0
1	Ultra Short Throw Projector LCD Technology - 3500 Lumens, WXGA Resolution (1280x800) w/ HDMI & VGA Inputs	Epson	EB-675Wi	1		0		0
2	Ultra Short Throw Projector Wall Mount bracket	Epson	ELPMB46	1		0		0
b)	Audio System (Mic System)							0

1	Rack mount 2-Channel, XLR/ ¼” I/O, w/o mics (Includes Base Station, Charger Base, Power Supply)	Revolabs	HD Venue 03-HDVENU- NM	1		0		0
2	HD Microphone, RF-Armor™ Wearable	Revolabs	Wearable 03-HDEXEMICEU-11	2		0		0
3	8 channel AEC microphone mixer with 4 Line Inputs and 8 Line outputs w/ built in USB Interface	Extron	DMP 128 Plus C 60-1512-01	1		0		0
c)	Audio System (Amplifier & Speaker)							0
1	Two Channel Amplifier - 200 Watts Per Channel	Extron	XPA 2002-70V 60-883-02	1		0		0
2	SpeedMount Two-Way Surface Mount Speakers with 8” Wooferr(Pairs)	Extron	SM-28T60-1309-13	1		0		0
d)	Video System							0

1	Two USB A Female to Two USB A Female on 10" Pigtails- Table Plate to be mounted on the Lectern	Extron	(70-454-13)	1		0		0
2	USB Patch Cables	Integrator	Custom	2		0		0
e)	Video & Control System							0
1	Male to Male VGA Micro HR with Audio Cables	Extron	MVGA-A M-M/6 (26-566-02)	2		0		0
2	Two Input DTP Transmitter for HDMI and VGA with Audio Embedding - Decorator-Style Wallplate	Extron	DTP T UWP 4K 232 D 60-1755-12	1		0		0
3	8x2 Seamless 4K Scaling Presentation Matrix Switcher with DTP Extension and Control Processor	Extron	DTP CrossPoint 82 4K IPCP SA 60-1583-12	1		0		0
4	DTP Receiver for HDMI - Decorator-Style Wallplate	Extron	DTP R HWP 4K 231 D 60-1531-13	1		0		0

5	7" Wall Mount Touchlink Pro Touchpanel	Extron	TLP Pro 725M 60-1563-03	1		0		0
6	Power Injector for XTP and Pro Series Control Systems	Extron	XTP PI 10060-1233-01	1		0		0
7	Ultra Flexible High Speed HDMI Cables-6'	Extron	HDMI Ultra/6 26-663-06	4		0		0
f)	Misc							0
1	Micro Tower- Intel® Core™ i5-7500 with Intel® HD Graphics 630 (3.4 GHz base frequency, up to 3.8 GHz with Intel® Turbo Boost Technology, 6 MB cache, 4 cores) Internal drive 1 TB 7200 rpm SATA 16 GB NVMe™ Intel® Optane™ Memory for storage acceleration, Intel® HD Graphics 630 HP USB Business Slim Keyboard HP USB Hardened	HP	ProDesk 400G4 Small Form Factor PC	1		0		0

	Mouse HP EliteDisplay E221 21.5-In Monitor Windows 10 Pro 64							
2	IP controlled Power conditioner 230 volt	APC	AP7921	1		0		0
3	Wireless Presentation Unit	WePreset	WiPG1000	1		0		0
4	12U Customised Equipment rack	Integrato r	Modular	1		0		0
5	Cables and Connectors Includes Audio, Speaker, Control, Microphone cables, Mounting	Integrato r	Various	1		0		0

	accessories, IEC Connectors etc							
C	Meeting Room							0
a)	Display System							0
1	Ultra Short Throw Interactive Projector- 4400 Lumens, WUXGA Resolution (1920x1200) w/ HDMI & VGA Inputs	Epson	EB-1460Ui	1		0		0
2	Ultra Short Throw Projector Wall Mount bracket	Epson	ELPMB46	1		0		0
3	USB based PTZ Camera HD Resolution with Wall Bracket	Logitech	PTZ PRO	1		0		0
4	Mini PC with Wireless Keyboard & Mouse	Apple + Logitech	Mac Mini + KBM	1		0		0
5	USB Based Conference Phone with Extension Microphones- to be used for UC based conferencing application like	Revolabs	FLXUC1500	1		0		0

	Skype, Zoom, WebEx etc							
6	USB Etxender	Modular	USB Ext	1		0		0
7	Wireless Presentation Unit	WePreset	WiPG1000	1		0		0
8	Wallplate with Pass-Through Connectors for HDMI, Computer Video, and PC Audio - MK Junction Boxes	Extron	WPC 220 A MK70-1032-03	1		0		0
9	Meeting Space Collaboration System	Extron	HC 404 42-268-01	1		0		0
10	Stereo Amplifier - 15 Watts Per Channel	Extron	MPA 152 Plus 60-844-03	1		0		0
11	SpeedMount Compact Full-Range Surface Mount Speakers (Pair)	Extron	SM 3 42-133-03	1		0		0
12	MediaLink Plus Controller	Extron	MLC Plus 100 60-1469-03	1		0		0

13	Power Injector for XTP and Pro Series Control Systems	Extron	XTP PI 100 60-1233-01	1		0		0
14	Ultra Flexible High Speed HDMI Cables-6'	Extron	HDMI Ultra/6 26-663-06	4		0		0
15	Male to Male VGA Micro HR with Audio Cables	Extron	MVGA-A M- M/6 (26-566-02)	2		0		0
16	Under Table Shelf System- Primary	Extron	UTS 100 70-1028-01	1		0		0
17	Under Table Shelf System- Secondary	Extron	UTS 150 70-1028-02	1		0		0
18	SpeedMount Compact Full-Range Surface Mount Speakers (Pair)	Extron	SMB 112 70-1097-02	1		0		0
19	Cables and Connectors Includes Audio, Speaker, Control, Microphone cables, Mounting accessories, IEC Connectors etc	Integrator	Various	1		0		0
	GRAND TOTAL					₹ 0		0

35 SEATER CLASSROOM - AUDIO, VIDEO & CONTROL SCHEMATICS

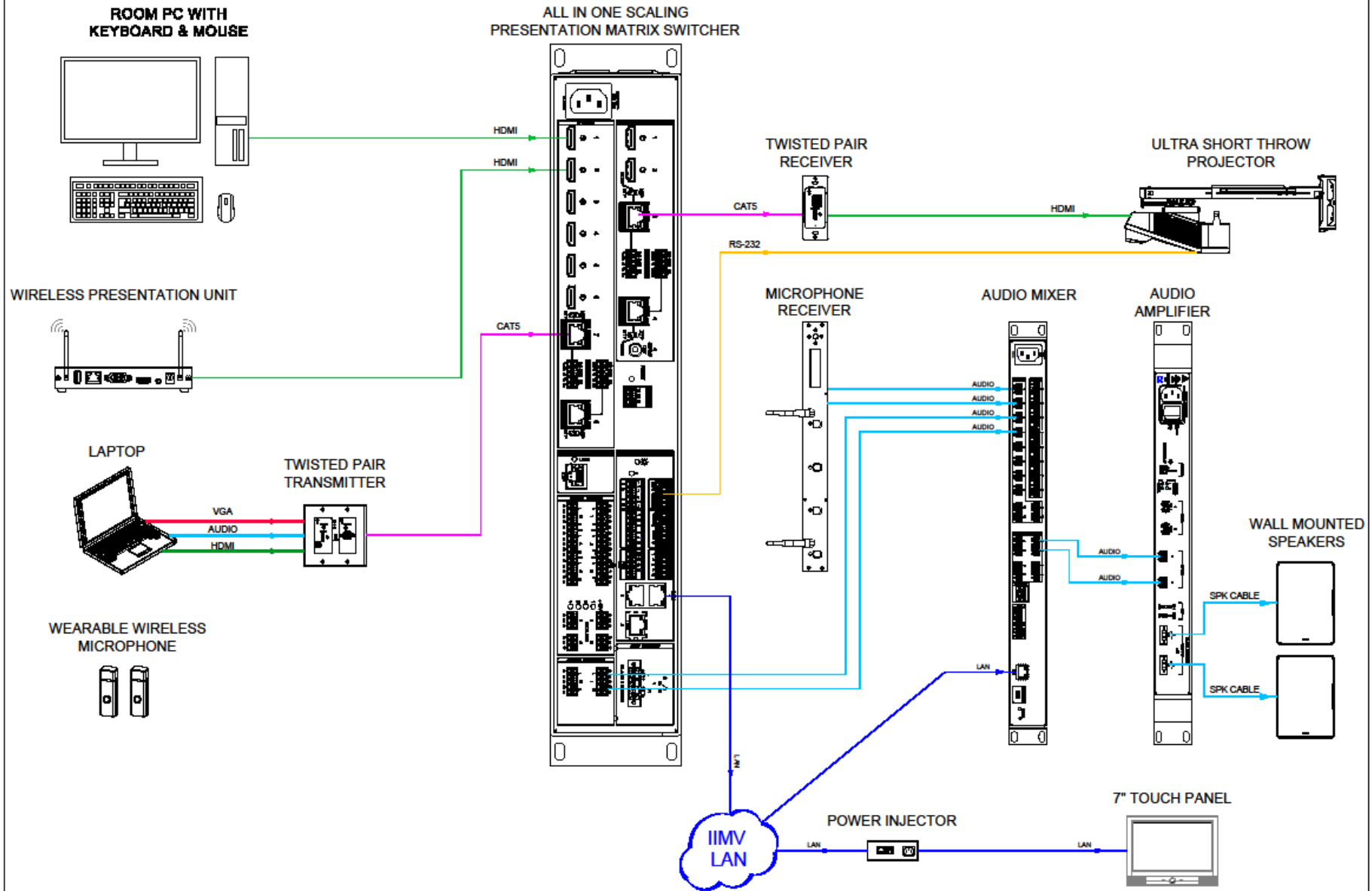

60 SEATER CLASSROOM - AUDIO, VIDEO & CONTROL SCHEMATICS

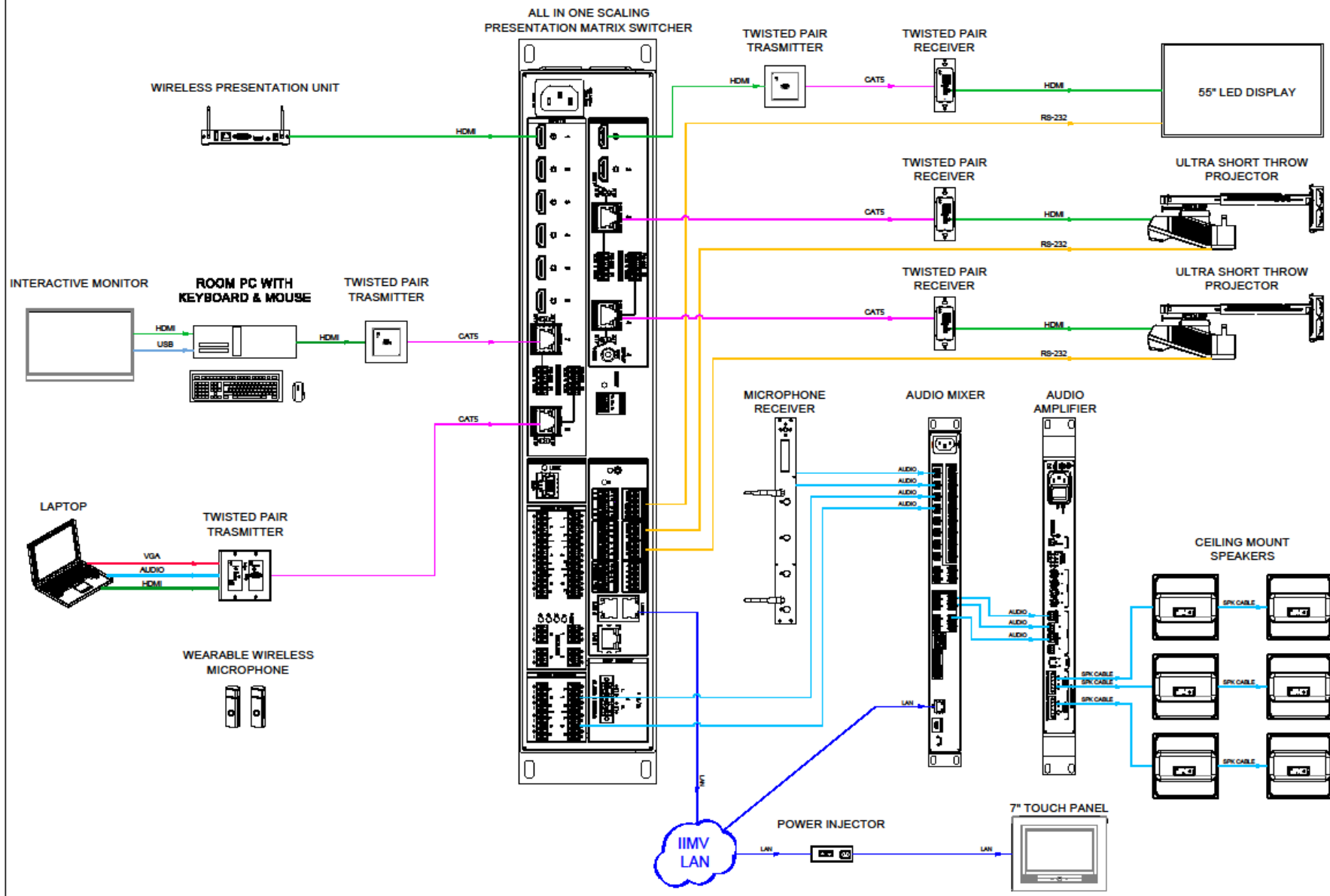

MEETING ROOM - AUDIO, VIDEO & CONTROL SCHEMATICS

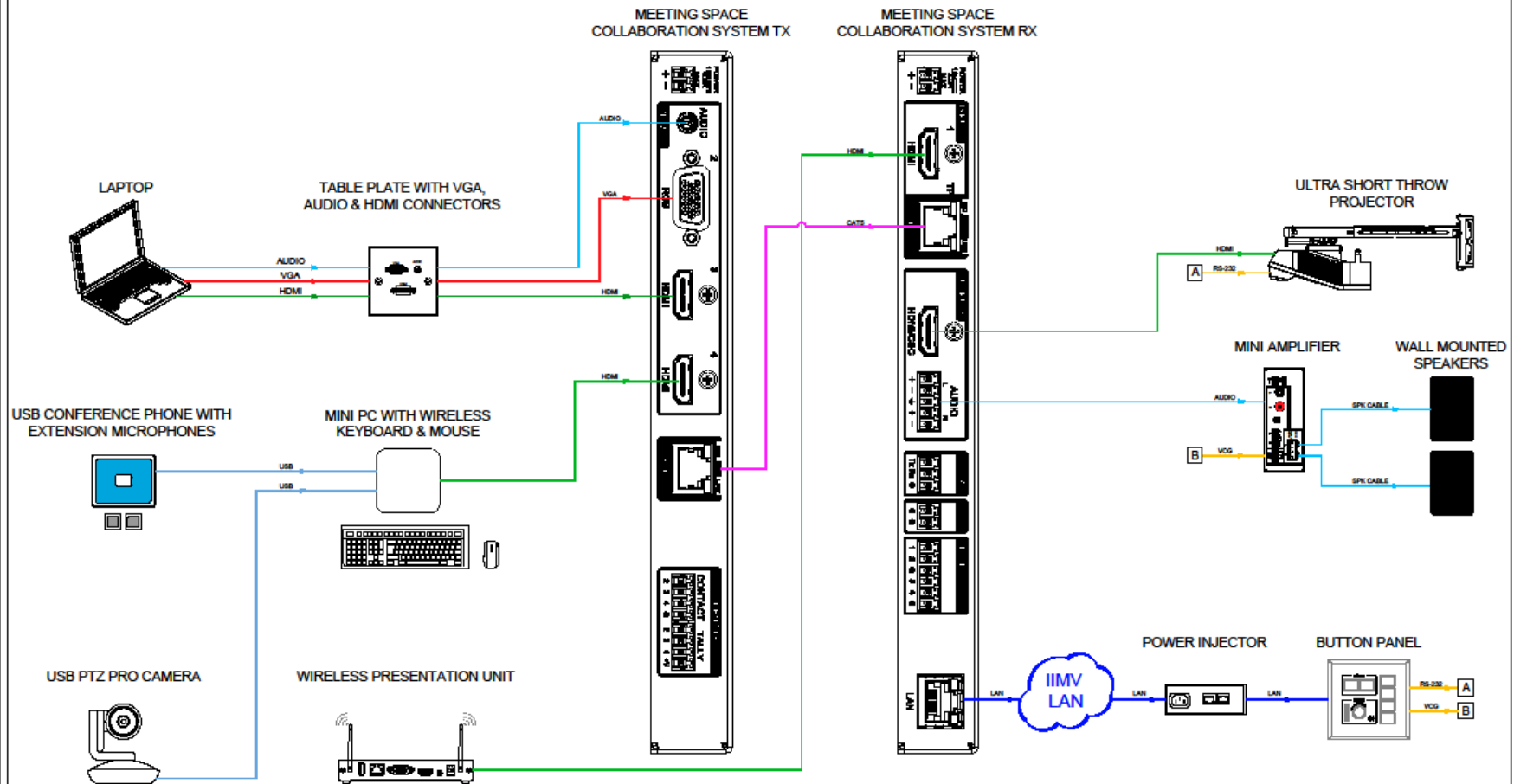



IIM

भारतीय प्रबंध संस्थान विशाखपट्टणम
Indian Institute of Management Visakhapatnam

E-Tender Notice

Indian Institute of Management Visakhapatnam invites electronic tender for “Tender for “Supply, Installation, Commissioning and Audio-Visual (AV) Systems for classrooms & Meeting room at IIM Visakhapatnam”.

The Tender document should be electronically submitted on or before **4.5.2018 at 3:00 PM.**

The details of e-tender notification and TENDER document bid can be downloaded at www.tenderwizard.com/IIMV or from IIMV website (www.iimv.ac.in)

For further details on eTender participation, please contact KEONICS Help desk on Ph.: 080-49352000 / 9686196760/ 9686196765
E-mail: Prabhuswamy@etenderwizard.com ; mohan@etenderwizard.com,

Sd/-

Project Manager-Infrastructure
Indian Institute of Management Visakhapatnam

TENDER EVENTS:

1	TENDER inviting date	25.04.2018
2	Tender No/Ref No/NIT No	IMV/PMO/T/04/2018-19
3	IIMV -Division Name	Projects/Estate/Engineering
4	E-Tender processing fee payable to KEONICS through e Payment mode using Credit/Debit/Net banking mode	Rs.5,000/-plus GST Applicable
5	Tender Processing Fee payable online only	1000/-
6	Earnest Money Deposit (EMD)/Bid Security payable online only	1,72,800/-
7	Remittance of e-Tendering processing fee for Online Closed Bidding, Training and downloading.	25.04.2018, 10:00 Hrs to 04.05.2018, 15:00 Hrs
8	Last Date and time of closing of Uploading of TENDER documents	04.05.2018, 15:00 Hrs

e-Tendering Guidelines to Vendors

1. Vendors must have Class 2/3 Digital Signature Certificate to participate in the tender (To obtain DSC, please contact KEONICS help desk)

Phone: 08040482113

Email id: hemamalini.s@antaressystems.com

Note: If Vendors already having Digital Signature Certificate then no need to buy the digital signature again.

2. Bidders should register themselves in the website www.tenderwizard.com/IIMV.

To activate the user ID and password, kindly pay the Registration fee of Rs.2, 000 plus

tax by paying online payment through credit card/Debit card /Net banking in the website.

3. Tender will not be accepted after the date and time fixed for receipt of tenders as set in Tender notice or subsequent extensions if any.

4. Relevant documents in proof have to be uploaded wherever required and Hard copy to be submitted.

HELPDESK:

To get in touch with one of our customer service representatives, please refer the help desk numbers provided on the homepage or call the following number:
Bangalore: 080 40482000

1. Prabhuswamy: 09686196760 / Prabhuswamy@etenderwizard.com
2. Mohan Kumar: 09686196765 / mohan@etenderwizard.com

Communication Address

KEONICS Help Desk
No. 24, 3rd stage, 4th Block,
Basaveshwaranagar,
Bangalore - 560079
Fax : 080 40482114

-o0o-